

REPAIR PARTS KITS		
DESCRIPTION	PART NO.	
DIAPHRAGM & SEALS KIT CONSISTS OF ITEM NO'S 4, 7(2), 8, 9, 10(2), 11, 12	1070110 (AV7-RA)	1070516(AV7-RAHT)
	INCLUDES DISC 1074490 (427-JH), DIAPHRAGM 1074475 (427-FB)	INCLUDES DISC 1074491 (427-JT), DIAPHRAGM 1074477 (427-FV)
INT. PARTS KIT (NORM. OPEN) CONSISTS OF STANDARD ITEM NO'S 11, 14, 15, 16, 17, 19	1070517 (AV7-RF)	
SEAT (ITEM NO. 3)	1074505	

ASSEMBLY TOOLS	
DESCRIPTION	PART NO.
FOR INSTALLATION & REMOVAL OF SHAFT GUIDE (ITEM #11) (NOT SHOWN)	1-3/16" HEX SOCKET

TORQUE TABLE		
ITEM#	DESCRIPTION	TORQUED TO (+/-10%)
3	SEAT	500 IN/LBS (41.6 FT/LBS)
10	UPPER NUT	140 IN/LBS
10	LOWER NUT	140 IN/LBS
5, 6, 13	NUT,HEX SCREW	140 IN/LBS
11	SHAFT GUIDE	500 IN/LBS (41.6 FT/LBS)

NOTE:
 1. AMERICAN NATIONAL STANDARD TAPER
 PIPE THREADS (NPT) PER ANSI B2.1-1968
 2. VALVES AVAILABLE WITH B.S.P.T. END
 CONNECTIONS.

REVISIONS				
ECN	REV.	DESCRIPTION	DATE	APP'D
1830	O	CATALOG SHEET UPDATE	6/10/21	TRK
2072	P	CATALOG SHEET UPDATE	5/18/22	TRK
2271	Q	CATALOG SHEET UPDATE	9/12/23	TRK

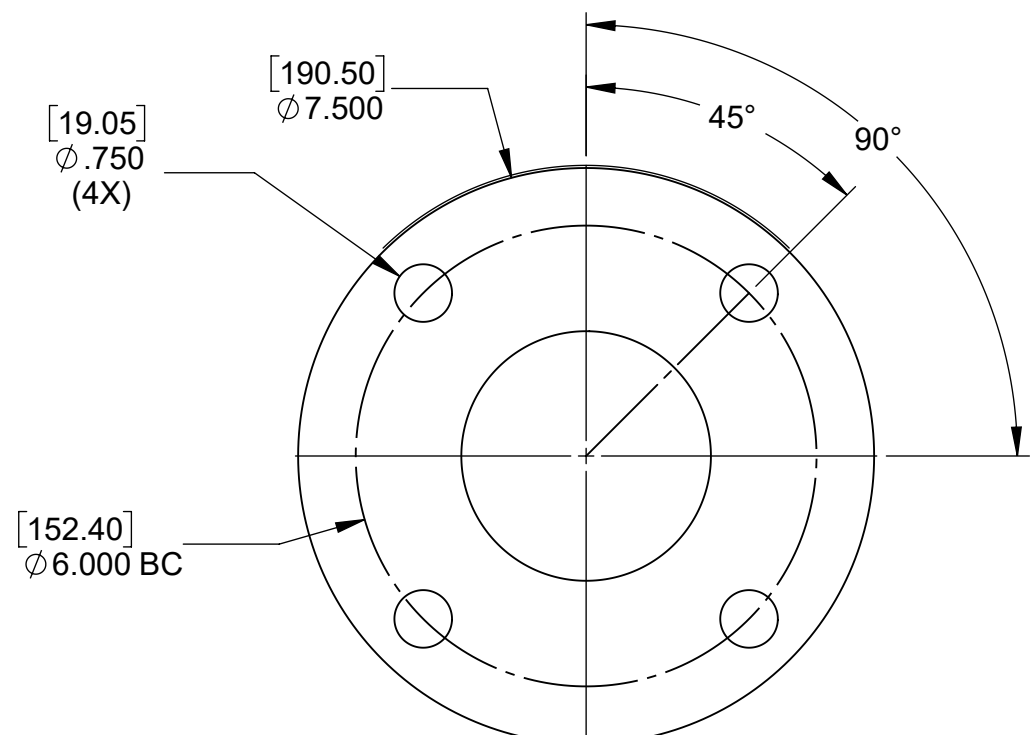

**AMERICAN FLANGE PER
A.S.A. 16.1 CLASS 125**

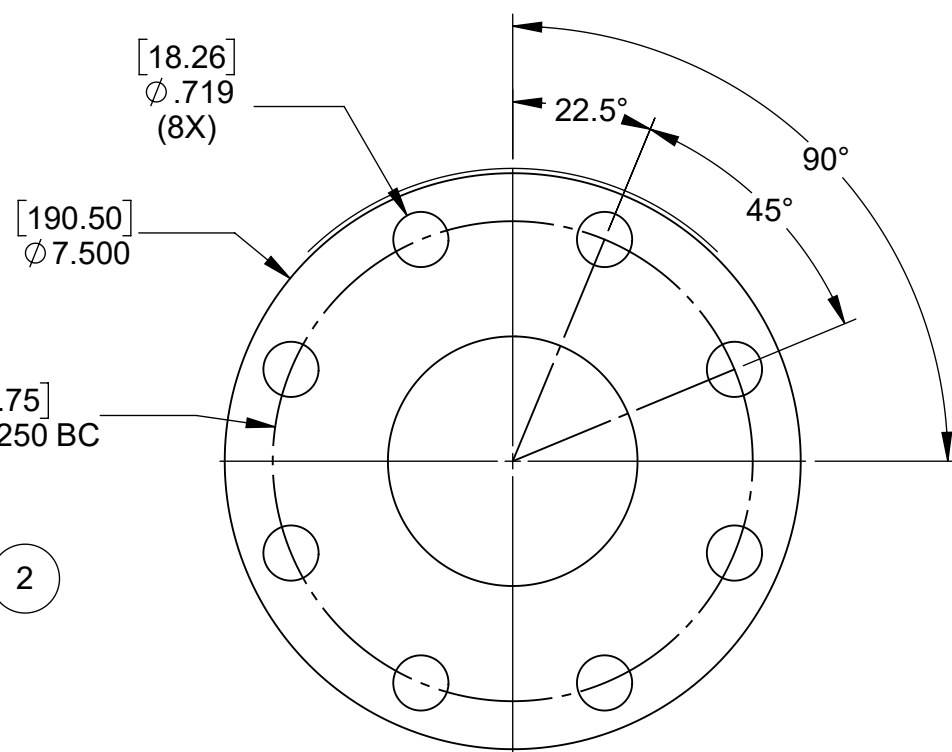

**METRIC FLANGE PER
BS4504. DIN 10 & ISO R 2084**

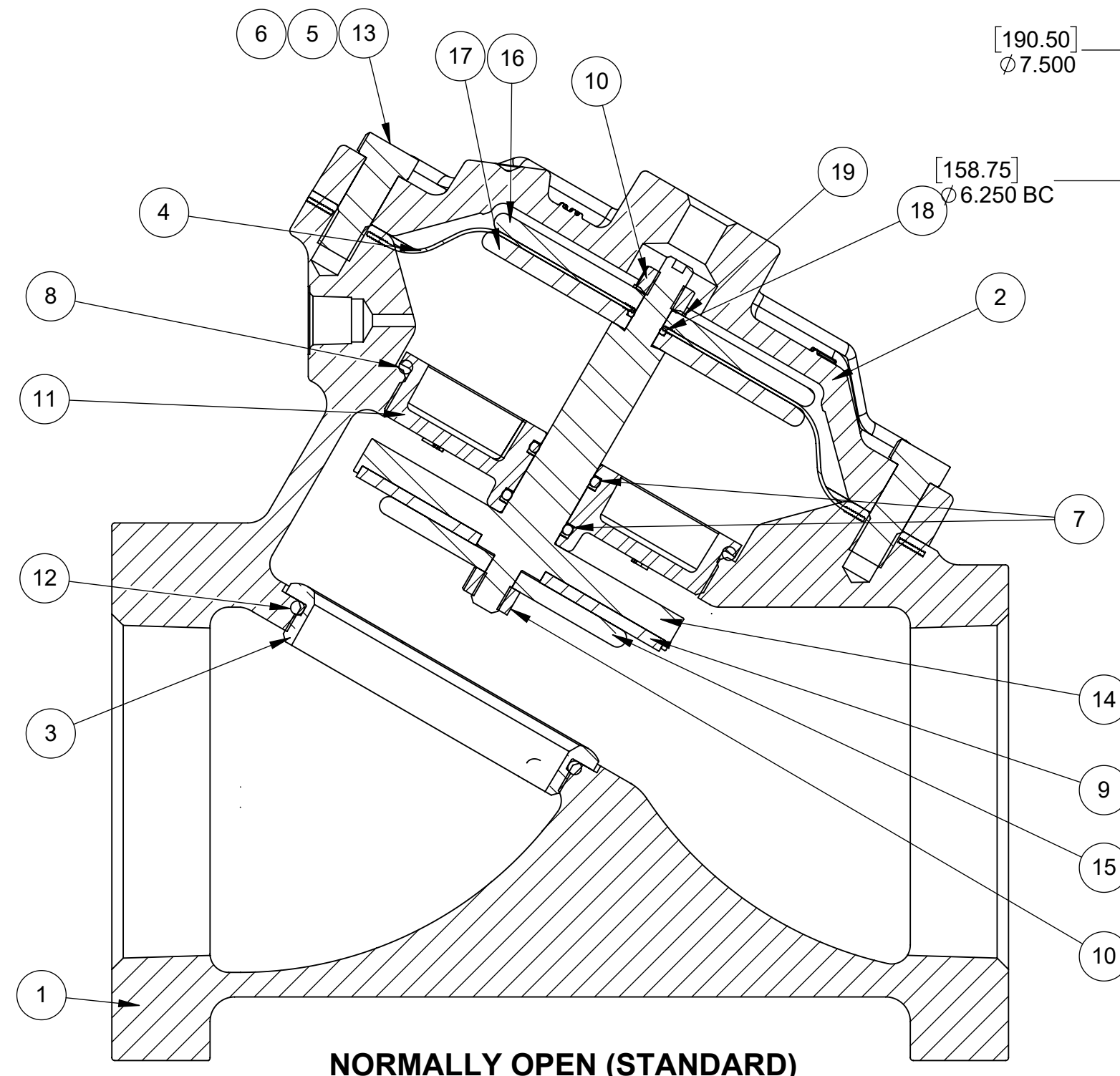

NORMALLY OPEN (STANDARD)

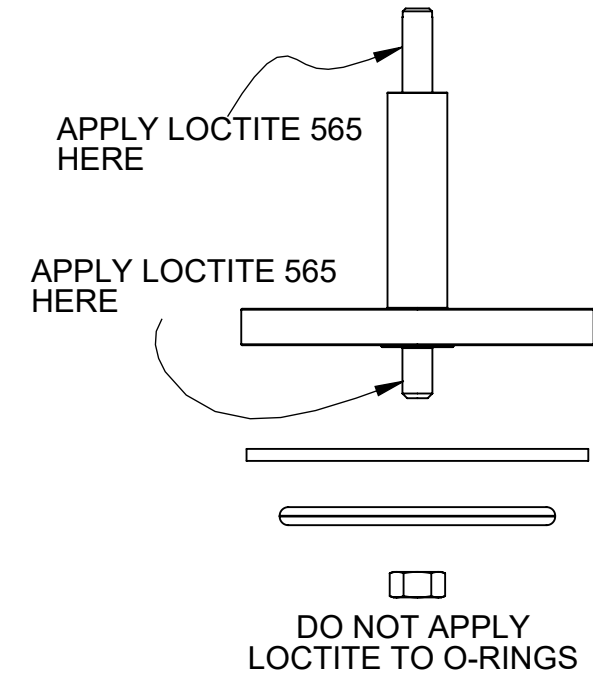

NORMALLY OPEN MODEL					
ITEM NO.	DESCRIPTION	STD.	PART NUMBER	QTY.	
1	BODY, 427,3.00" NPT THREAD	THREADED	* 1074446 (427-AS)	1	
	BODY, 427, A.S.A 16.1 TYPE	FLANGED	1074438		
	BODY, 427, METRIC TYPE	FLANGED	1074439		
2	CAP, 427, MACHINED	CAST IRON	* 1074454 (427-C)	1	
3	SEAT, 427, MACHINED	BRASS	* 1074505 (427-MO)	1	
4	DIAPHRAGM, 427	BUNA-N	* 1074475 (427-FB)	1	
		FKM	1074477 (427-FV)		
5	SCREW, 3/8" X 16 X 1 1/2", HX HD	PLATED STEEL	* 1072405 (SC2-0025)	6	
6	HEX NUT, 3/8" - 16	PLATED STEEL	* 1071658 (NUZ-0014)	6	
7	O-RING 2-114	ALFAS	* 1071691 (ORB-114TC)	2	
8	O-RING 2-237	FKM	* 1071708 (ORB-237)	1	
9	DISK	HYCAR	* 1074487 (427-J)	1	
10	NUT, HEX. 5/16" - 24	STAINLESS STEEL	* 1263853 (RMET)	2	
11	SHAFT GUIDE, MACHINED	STAINLESS STEEL	* 43850	1	
12	O-RING, 2-233	FKM	* 1071754 (ORE-233)	1	
13	SCREW,HEX HD, 3/8"-16X1	STAINLESS STEEL	* 19768	2	
14	SHAFT NORMALLY OPEN	STAINLESS STEEL	* 4510301-01	1	
15	DIAPHRAGM / DISC PLATE	STAINLESS STEEL	* 1074371 (426-DA)	1	
16	DIAPHRAGM PLATE	STAINLESS STEEL	* 1074472 (427-DA)	1	
17	DIAPHRAGM PLATE, LOWER	STAINLESS STEEL	* 1074473	1	
18	O-RING, 2-011	FKM	* 1071786 (ORV-011)	1	
19	LOCKWASHER	STAINLESS STEEL	* 1073590	1	

SEE REVERSE SIDE FOR CONFIGURATION OPTIONS

THIS DOCUMENT IS SOLELY THE PROPERTY OF AQ-MATIC REPRODUCTION, USE DISCLOSURE, OR TRANSMISSION OF THIS DOCUMENT OR DETAILS CONTAINED HEREIN, IN PART OR IN WHOLE, IS PROHIBITED WITHOUT THE WRITTEN CONSENT OF AQ-MATIC ENGINEERING. THIS DOCUMENT AND ANY COPIES SHALL BE RETURNED TO AQ-MATIC UPON WRITTEN REQUEST.

INTERPRET DIMENSIONS AND TOLERANCES PER ASME Y14.5M -1994

UNLESS OTHERWISE SPECIFIED:
 DIMENSIONS ARE IN INCHES (mm)
 CORNER FILLETS R.005-.020 [127-508]
 TOLERANCES:
 ANGLES : ±1°
 1 PLACE .X: ±.100 [2.54]
 2 PLACE .XX: ±.010 [0.25]
 3 PLACE .XXX: ±.005 [0.13]

THIRD ANGLE PROJECTION		DESCRIPTION CATALOG SHEET, VAV7 DIAPHRAGM VALVE STANDARD MODEL	
APPROVALS	DATE	SIZE C	DWG NO. 1077639
DRAWN TRK	1/22/21	SCALE 1:2	REV. Q
CHECKED BY		SOLIDWORKS FORMAT	SHEET 1 OF 2
APPROVED			

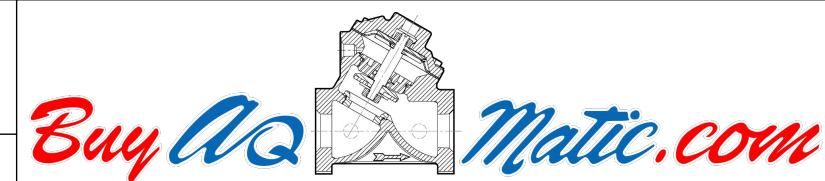

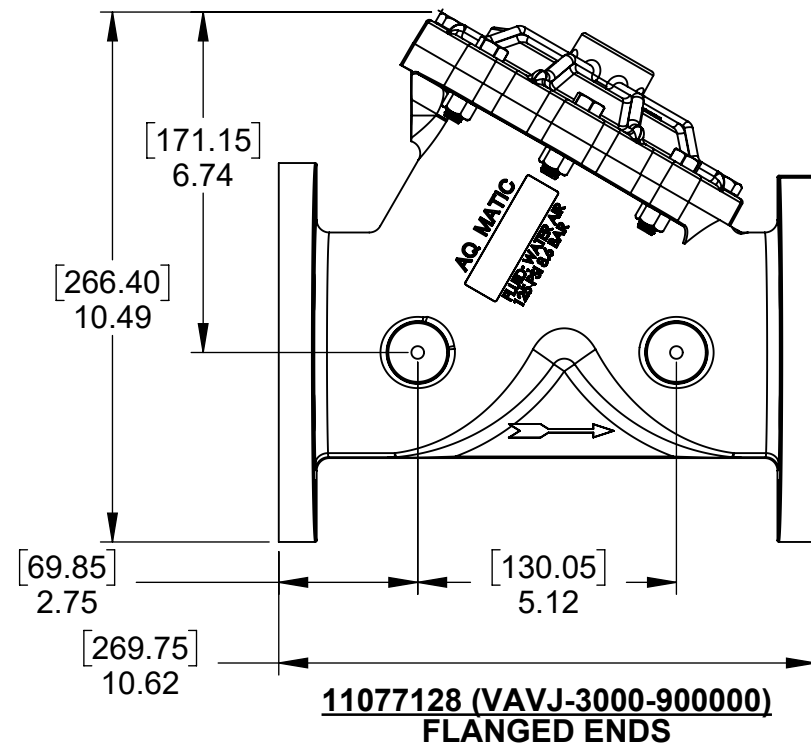
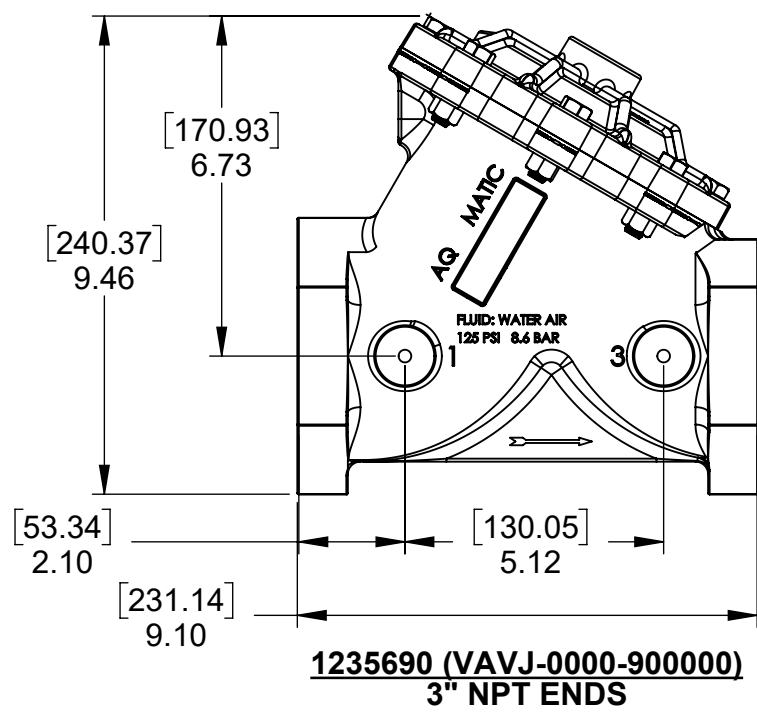

NOTE:
1. AMERICAN NATIONAL STANDARD TAPER PIPE THREADS (NPT) PER ANSI B2.1-1968
2. VALVES AVAILABLE WITH B.S.P.T. END CONNECTIONS.

REVISIONS				
ECN	REV.	DESCRIPTION	DATE	APP'D
		SEE PAGE 1 FOR REVISION UPDATES		

NORMALLY CLOSED MODEL				
ITEM NO.	DESCRIPTION	STD.	PART NUMBER	QTY.
20	SHAFT NORMALLY CLOSED	STAINLESS STEEL	* 4510301-02	1
21	PIPE PLUG 1/4" NPT	PLATED STEEL	* 1071918 (PLZ-0008)	1

SPRING ASSIST CLOSED MODEL				
ITEM NO.	DESCRIPTION	STD.	PART NUMBER	QTY.
22	MALE PIPE PLUG (1/8" NPT)	BRASS	* 1071903 (PLZ-0007)	1
23	NUT, SPRING RETAINER	BRASS	* 1074431 (425-TTA)	1
24	COMPRESSION SPRING	STAINLESS STEEL	* 1074429 (426-SSB)	1
25	O-RING, 2-025	BUNA-N	* 1071677 (ORB-025)	1
26	CAP, MACHINED, SPRING ASSIST	CAST IRON	* 1074460	1

SPRING ASSIST OPEN MODEL				
ITEM NO.	DESCRIPTION	STD.	PART NUMBER	QTY.
27	CENTERING WASHER	BRASS	* 1074436 (426-V)	1
28	SPRING, COMPRESSION	STAINLESS STEEL	* 1078692	1

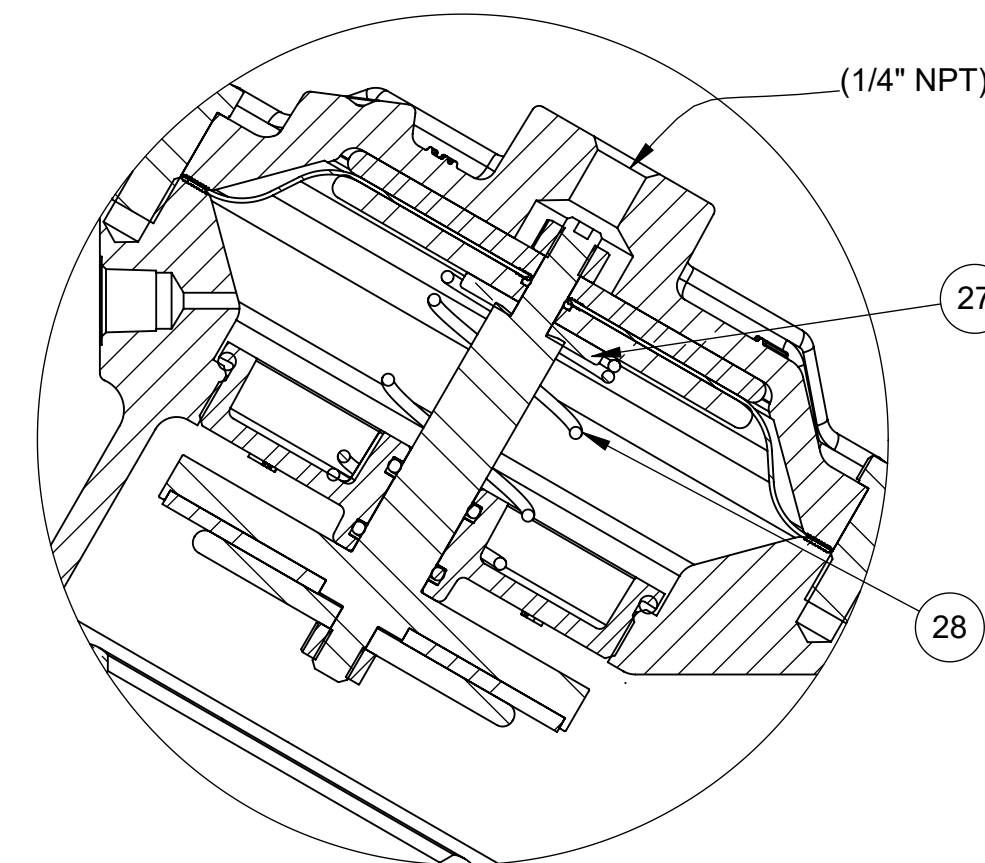
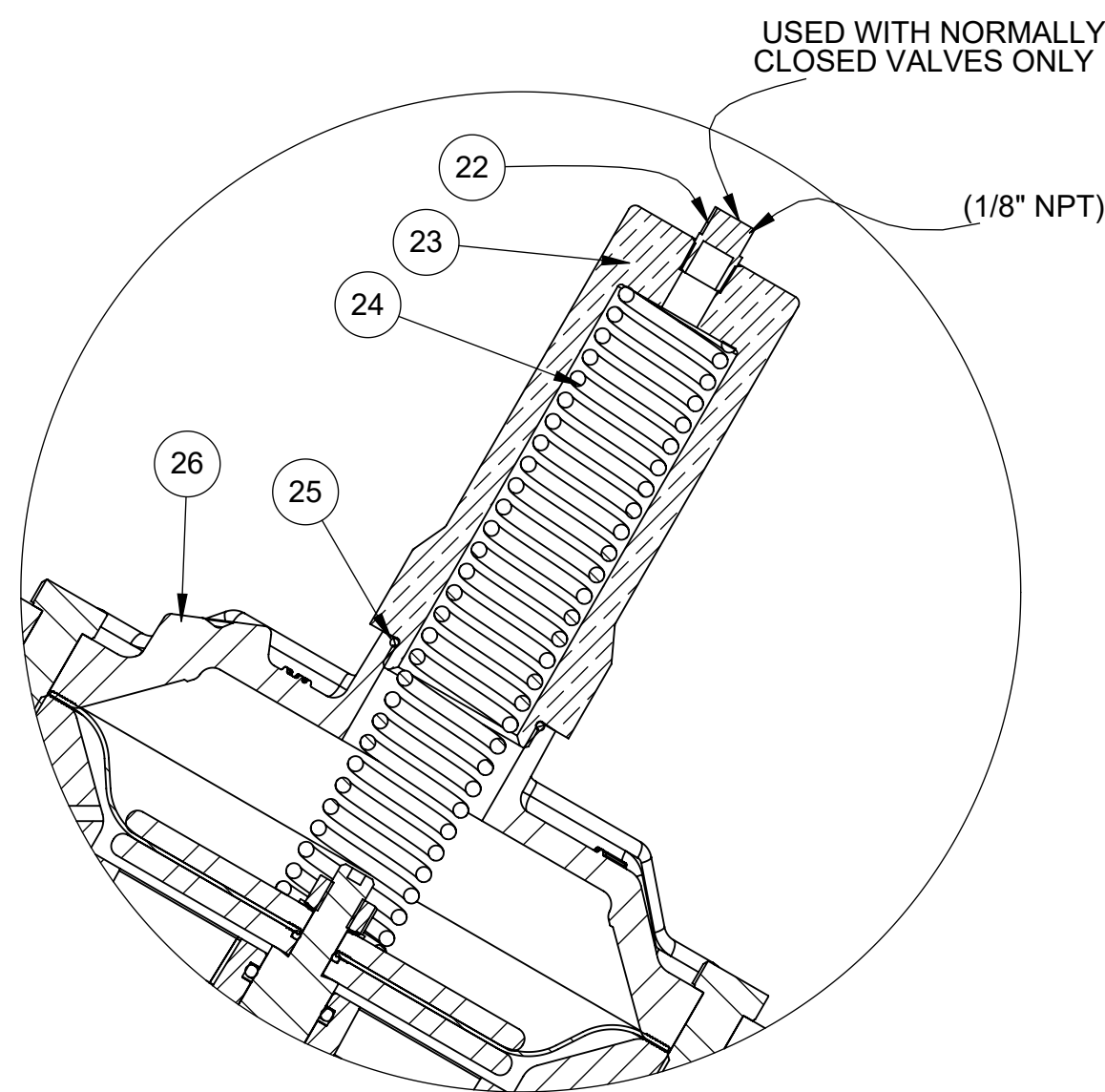
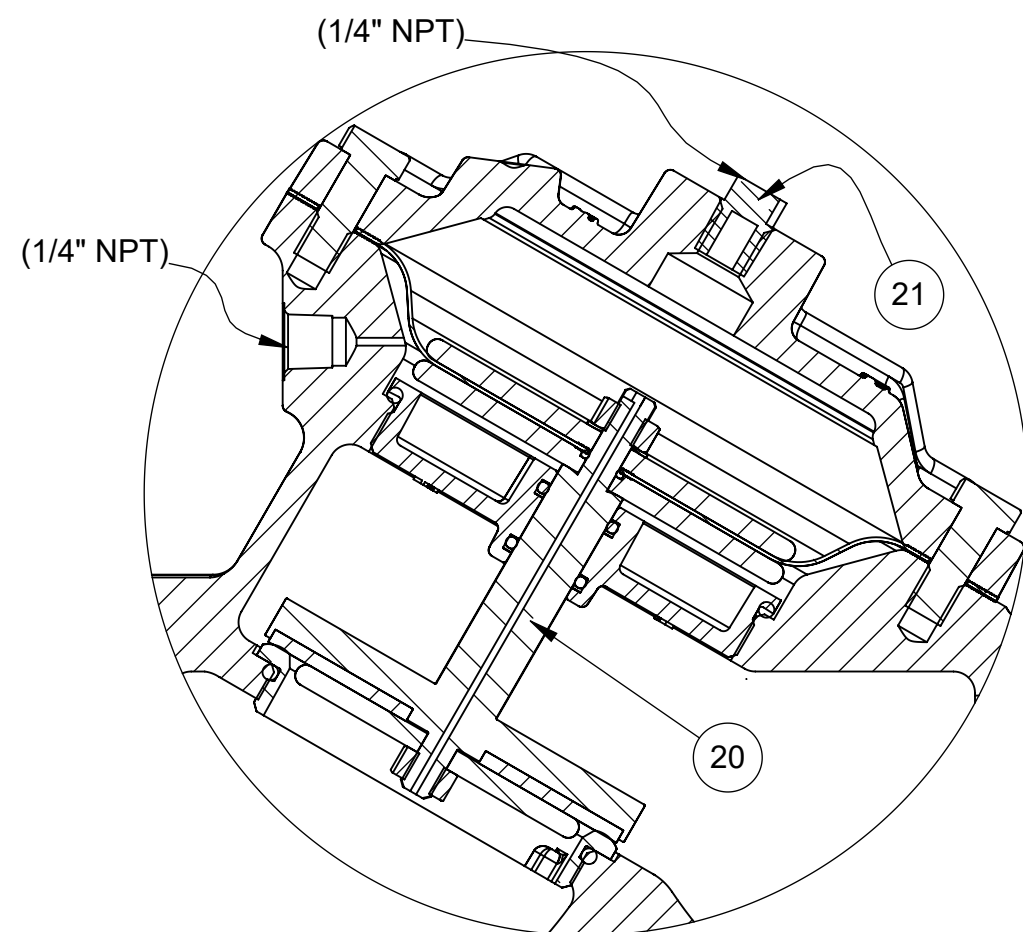

1269740 (VAVJ-0030-90000) (THREADED)
1242257 (VAVJ-3030-00000) (FLANGED)
NORMALLY CLOSED

3018900 (VAVJ-0002-90000) (THREADED)
1080797 (VAVJ-3002-90000) (FLANGED)
SPRING ASSIST CLOSED

1072502 (VAVJ-0001-90000) (THREADED)
1072509 (VAVJ-3001-00000) (FLANGED)
SPRING ASSIST OPEN

CONVERSION KITS	
DESCRIPTION	PART NO.
CONVERSION KIT (SPRING ASSIST CLOSED) CONSISTS OF STANDARD ITEM NO'S 22 THRU 26	1070519 (AV-SCC)
CONVERSION KIT (SPRING ASSIST OPEN) CONSISTS OF STANDARD ITEM NO'S 27, 28	1070520 (AV7-SO)

REPAIR PARTS KITS	
DESCRIPTION	PART NO.
INT. PARTS KIT (NORM. CLOSED) CONSIST OF STANDARD ITEM NO'S, 11, 15, 16, 17, 19, 21	1070518 (AV7-RG)
INT. PARTS KIT (SPRING ASSIST CLOSED) CONSIST OF STANDARD ITEM NO'S 24, 25	1070513 (AVG-SC)
INT. PARTS KIT (SPRING ASSIST OPEN) CONSIST OF STANDARD ITEM NO'S 27, 28	1070520 (AV7-SO)

SEE REVERSE SIDE FOR NORMALLY OPEN MODEL

THIS DOCUMENT IS SOLELY THE PROPERTY OF AQ-MATIC REPRODUCTION, USE DISCLOSURE, OR TRANSMISSION OF THIS DOCUMENT OR DETAILS CONTAINED HEREIN, IN PART OR IN WHOLE, IS PROHIBITED WITHOUT THE WRITTEN CONSENT OF AQ-MATIC ENGINEERING. THIS DOCUMENT AND ANY COPIES SHALL BE RETURNED TO AQ-MATIC UPON WRITTEN REQUEST.

INTERPRET DIMENSIONS AND TOLERANCES PER ASME Y14.5M-1994

UNLESS OTHERWISE SPECIFIED:
DIMENSIONS ARE IN INCHES (mm)
CORNER FILLETS R.005-.020 [127-508]
TOLERANCES:
ANGLES: ±1°
1 PLACE .X: ±.100 [2.54]
2 PLACE .XX: ±.010 [0.25]
3 PLACE .XXX: ±.005 [0.13]

THE COMPONENT OR PRODUCT DESCRIBED IN THIS DOCUMENT MUST COMPLY WITH RoHS 3 EU (EUROPEAN UNION) DIRECTIVE 2015/863

THIRD ANGLE PROJECTION

APPROVALS DATE
DRAWN TRK 1/22/21

CHECKED BY APPROVED

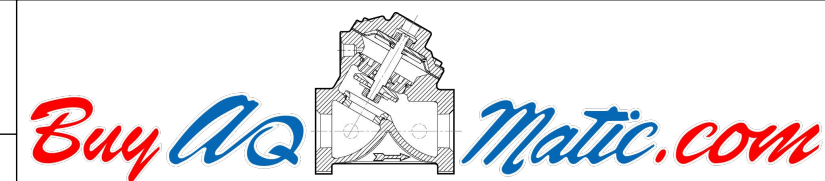

DESCRIPTION
**CATALOG SHEET, VAV7
DIAPHRAGM VALVE STANDARD MODEL**

SIZE C DWG NO. 1077639 REV. Q

SCALE 1:2 SOLIDWORKS FORMAT SHEET 2 OF 2