

REVISIONS				
ECN	REV.	DESCRIPTION	DATE	APP'D
1823	L	CATALOG SHEET UPDATE, COMPONENT CHANGES	1/20/21	TRK
2139	M	CATALOG SHEET UPDATE, PART TO PRINT	9/20/22	TRK
2171	N	REPLACED 1074226 (SHAFT GUIDE) WITH 43852	1/26/23	TRK
2271	P	REMOVE DISC 1074235 FROM BOM	9/13/23	TRK

REPAIR PARTS KITS		
DISCRIPTION	PART NO.	
DIAPHRAGM & SEALS KIT CONSISTS OF ITEM NO'S 6, 7, 9, 11, 12, 14, 15, 16	1070107 (AV4-RA)	1070502 (AV4-RAHT)
	INCLUDES DISC 1074234 (424-JH) DIAPHRAGM 1074222 (424-FB)	INCLUDES DISC 1074235 (424-JT) DIAPHRAGM 1074224 (424-FV)
INT. PARTS KIT (NORM. OPEN) CONSISTS OF STANDARD ITEM NO'S 5(2), 8, 10, 17	1070119 (424-RF)	
SEAT (ITEM NO. 13)	1074245 (424-MO)	

- NOTE:
- AMERICAN NATIONAL STANDARD TAPER PIPE THREADS (NPT) PER ANSI B2.1-1968
 - VALVES AVAILABLE WITH B.S.P.T. END CONNECTIONS.

ASSEMBLY TOOLS	
DESCRIPTION	PART NO.
FOR INSTALLATION & REMOVAL OF SEAT (ITEM NO. 13) (TOOL NOT SHOWN)	1074247 (424-MT)
FOR INSTALLATION AND REMOVAL OF SHAFT GUIDE (ITEM#7) 3/4" HEX. SOCKET DRIVER	1074227 (424-GT)

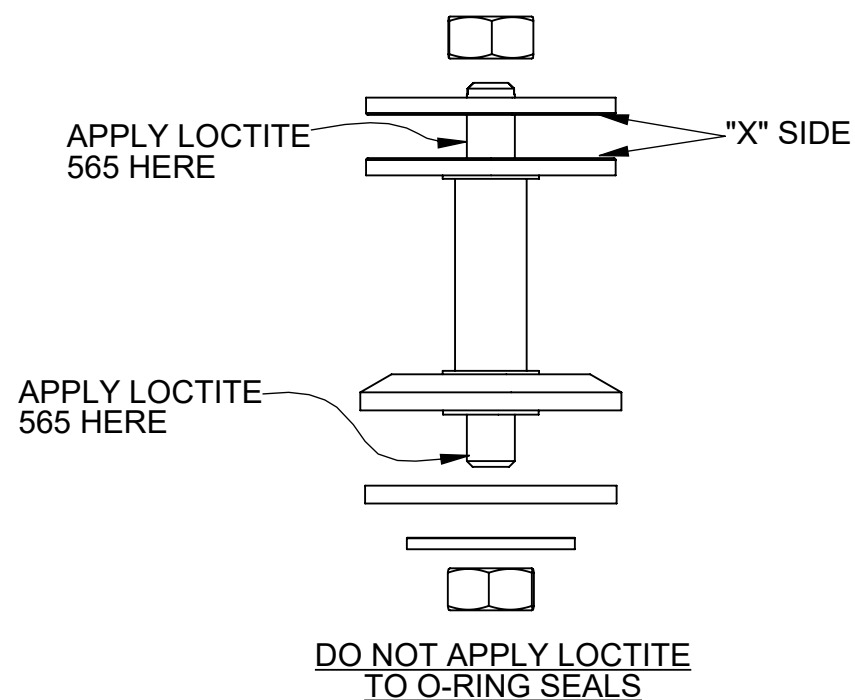

NORMALLY OPEN (STANDARD)					
ITEM NO.	DESCRIPTION	STD.	PART NUMBER	QTY.	
1	MACHINED BODY	CAST IRON	1-1/4" NPT	* 1074196 (424-A5)	1
			1-1/2" NPT	* 1074199 (424-A6)	
			1-1/4" BSPT	1074197 (424-A5-BSPT)	
			1-1/2" BSPT	1074200 (424-A6-BSPT)	
2	CAP, NPT TAP TOP	CAST IRON	* 1074202 (424-C)	1	
3	HEX NUT 1/4" - 20	PLATED STEEL	* 1071656 (NUZ-0008)	4	
4	HEX SCREW 1/4" - 20	PLATED STEEL	* 1072399 (SCZ-0007)	4	
5	DIAPHRAGM PLATE	STAINLESS STEEL	* 43943	2	
6	HEX NUT 5/16 - 24	STAINLESS STEEL	* 1263853 (RMET)	1	
			BUNA N		* 1074222 (424-FB)
7	DIAPHRAGM, 424	FKM	1074224 (424-FV)	1	
			STAINLESS STEEL		* 43852
8	SHAFT GUIDE (REQ'S ASSY TOOL)	STAINLESS STEEL	* 43852	1	
9	O-RING 2-132	FKM	* 1071806 (ORV-132)	1	
10	NORMALLY OPEN COMBO SHAFT	STAINLESS STEEL	* 44013	1	
11	DISC	HYCAR	* 1074234 (424-JH)	1	
12	HEX NUT (1/4"-28)	STAINLESS STEEL	* 1263852 (NUS-0010)	1	
13	SEAT - BRASS (REQ'S ASSY TOOL)	BRASS	* 1074245 (424-MO)	1	
14	COPPER GASKET	COPPER	* 1074252 (424-R)	1	
15	O-RING 2-110	AFLAS	* 1071661	1	
16	O-RING 2-028	FKM	* 1071793 (ORV-028)	1	
17	DISC PLATE	STAINLESS STEEL	* 43942 (424-H)	1	

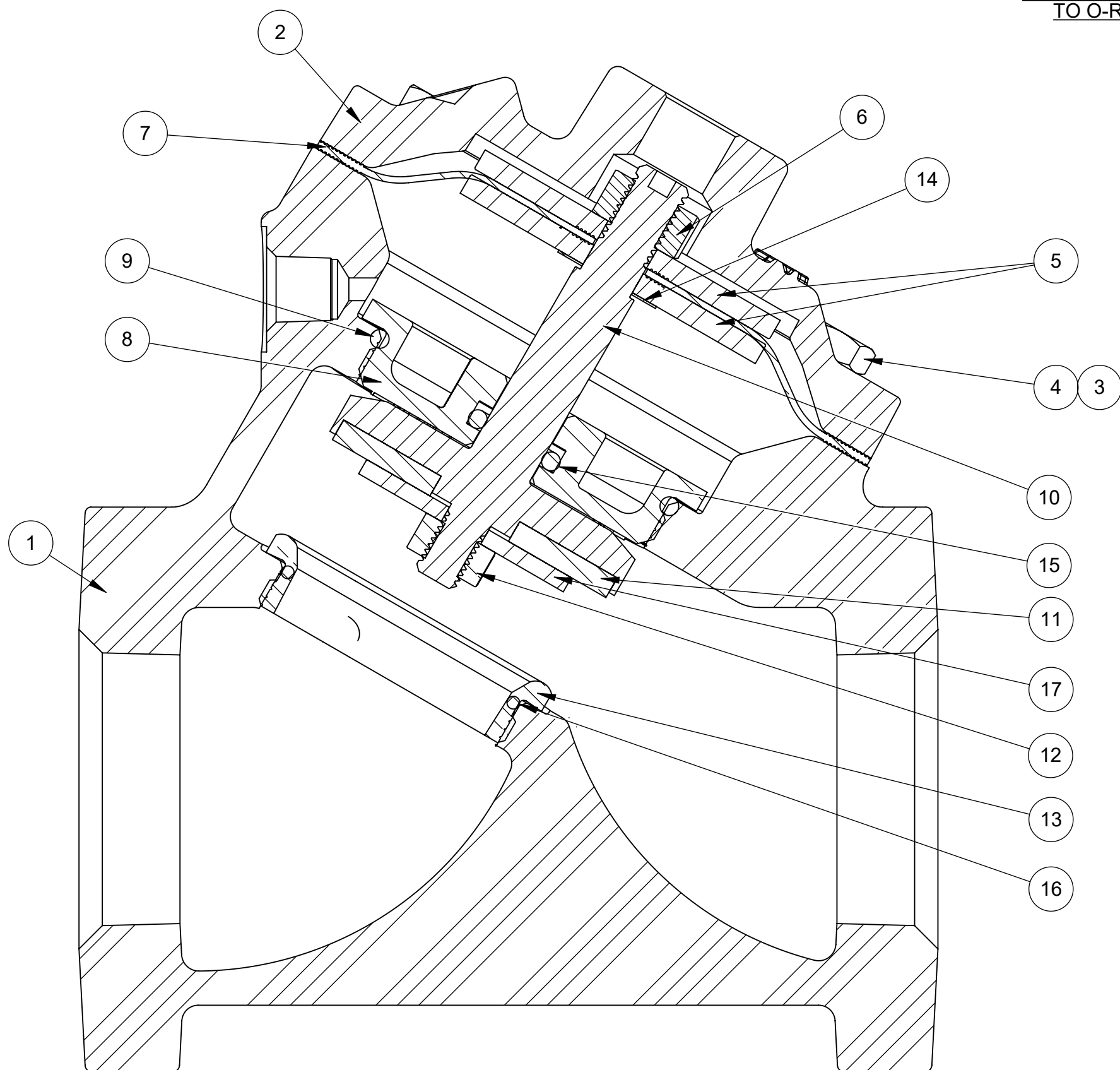

TORQUE TABLE		
ITEM #	DESCRIPTION	TORQUED TO (+/- 10%)
13	SEAT	120 IN/LBS
12	LOWER NUT	90 IN/LBS
8	SHAFT GUIDE	120 IN/LBS
6	UPPER NUT	90 IN/LBS
3 & 4	NUT & CAP SCREW	90 IN/LBS

4500196 (VAVD-0000-90000) (1-1/4" NPT)
 1072475 (VAVE-0000-90000) (1-1/2" NPT)
NORMALLY OPEN (STANDARD)

SEE SHEET 2 FOR CONFIGURATION OPTIONS

THIS DOCUMENT IS SOLELY THE PROPERTY OF AQ-MATIC REPRODUCTION, USE DISCLOSURE, OR TRANSMISSION OF THIS DOCUMENT OR DETAILS CONTAINED HEREIN, IN PART OR IN WHOLE, IS PROHIBITED WITHOUT THE WRITTEN CONSENT OF AQ-MATIC ENGINEERING. THIS DOCUMENT AND ANY COPIES SHALL BE RETURNED TO AQ-MATIC UPON WRITTEN REQUEST.

INTERPRET DIMENSIONS AND TOLERANCES PER ASME Y14.5M -1994

UNLESS OTHERWISE SPECIFIED:
 DIMENSIONS ARE IN INCHES (mm)
 CORNER FILLETS R.005-.020 (.127-.508)
 TOLERANCES:
 ANGLES: ±1°
 1 PLACE .X: ±.100 (2.54)
 2 PLACE .XX: ±.010 (0.25)
 3 PLACE .XXX: ±.005 (0.13)

THE COMPONENT OR PRODUCT DESCRIBED IN THIS DOCUMENT MUST COMPLY WITH RoHS 3 EU (EUROPEAN UNION) DIRECTIVE 2015/863



APPROVALS	DATE
DRAWN TRK	1/20/21
CHECKED BY	
APPROVED	

Buy AQ Matic.com

DESCRIPTION
CATALOG SHEET, VAV4, DIAPHRAGM VALVE

SIZE **C** DWG NO. **1077636** REV. **P**

SCALE **1:2** SOLIDWORKS FORMAT SHEET 1 OF 2

REVISIONS

ECN	REV.	DESCRIPTION	DATE	APP'D
1823	L	CATALOG SHEET UPDATE, COMPONENT CHANGES	1/20/21	TRK
2139	M	CATALOG SHEET UPDATE, PART TO PRINT	9/20/22	TRK
2171	N	REPLACED 1074226 (SHAFT GUIDE) WITH 43852	1/26/23	TRK
2271	P	REMOVE DISC 1074235 FROM BOM	9/13/23	TRK

REPAIR PARTS KIT	
DESCRIPTION	PART NO.
INT. PARTS KIT (NORM. CLOSED) CONSISTS OF STANDARD ITEM NO'S 5(2), 8, 17, 18	1070130 (424-RG)
INT. PARTS KIT (SPRING ASSIST CLOSED) CONSISTS OF STANDARD ITEM NO'S 22, 23, 24	1074265 (424-SC)
INT. PARTS KIT (SPRING ASSIST OPEN) CONSISTS OF STANDARD ITEM NO'S 14, 26, 27	1074268 (424-SO)

CONVERSION KITS	
DESCRIPTION	PART NO.
CONVERSION KIT (SPRING ASSIST CLOSED) CONSISTS OF STANDARD ITEM NO'S 20 THRU 25	1074266 (424-SCC)
CONVERSION KIT (SPRING ASSIST OPEN) CONSISTS OF STANDARD ITEM NO'S 8, 14, 26, 27	1074269 (424-SOC)

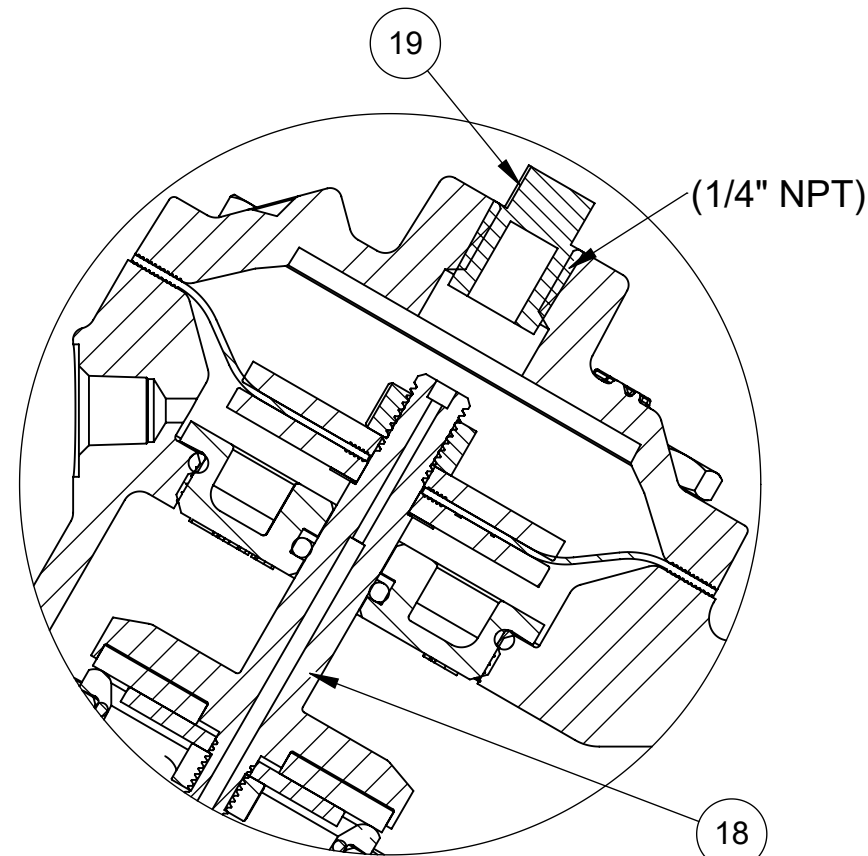

4500197 (VAVD-0030-90000)(1-1/4" NPT)
 1072479 (VAVE-0030-90000)(1-1/2" NPT)
NORMALLY CLOSED

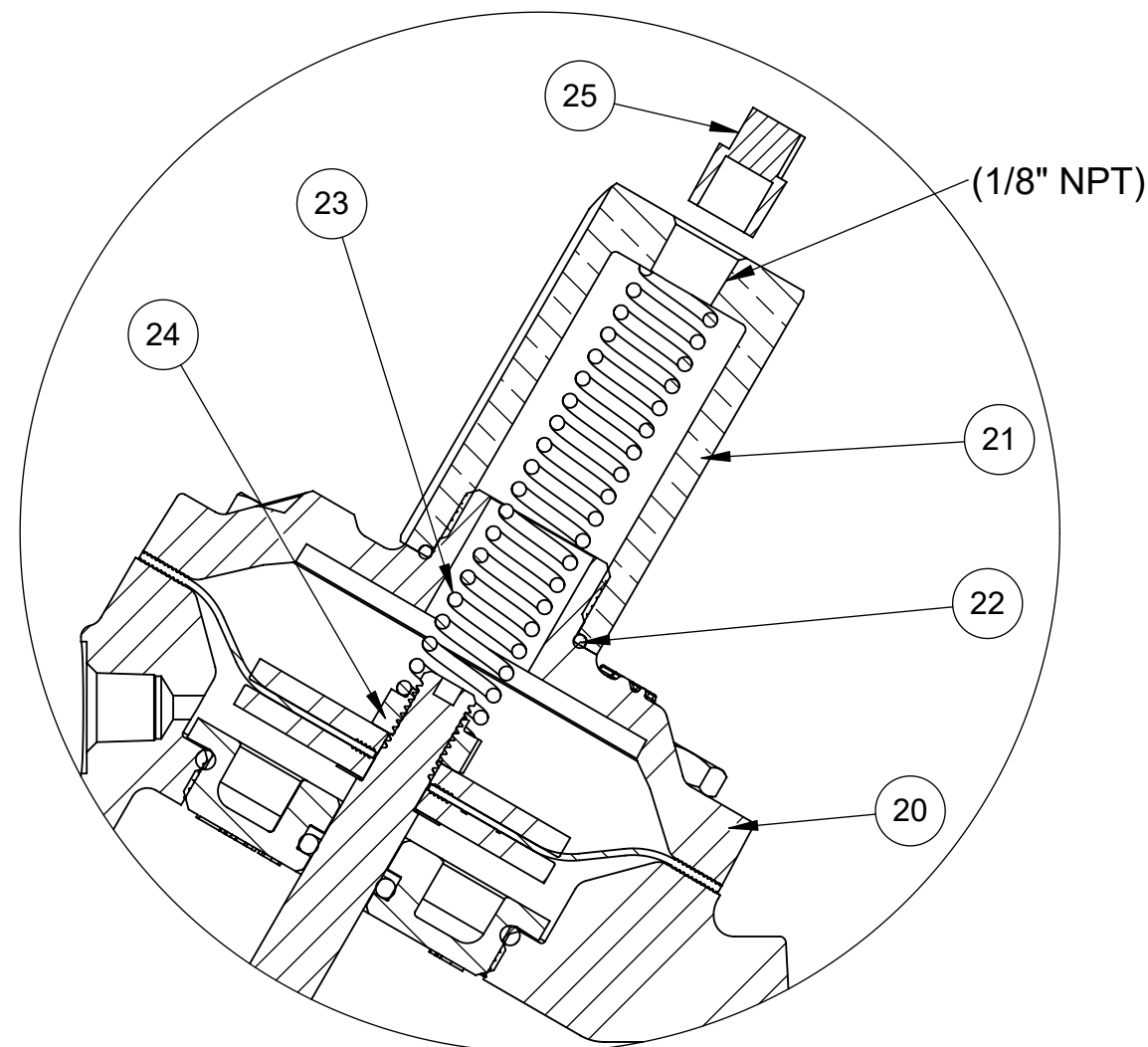

1072472 (VAVD-0002-90000)(1-1/4" NPT)
 1072477 (VAVE-0002-90000)(1-1/2" NPT)
SPRING ASSIST CLOSED

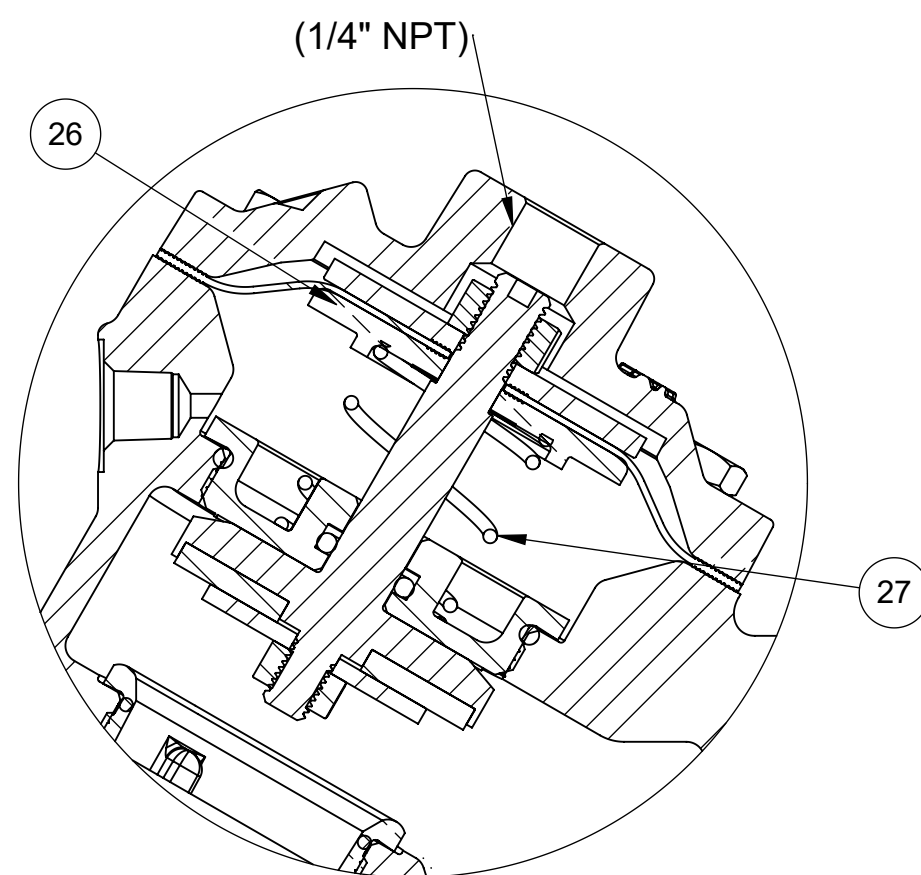

1072471 (VAVD-0001-90000)(1-1/4" NPT)
 1070064 (VAVE-0001-90000)(1-1/2" NPT)
SPRING ASSIST OPEN

TORQUE TABLE		
ITEM #	DESCRIPTION	TORQUED TO (+/- 10%)
21	RETAINER NUT	120 IN/LBS
24	CENTERING NUT	90 IN/LBS

NORMALLY CLOSED MODEL

ITEM NO.	DESCRIPTION	STD	PART NUMBER	QTY.
18	NORMALLY CLOSED COMBO SHAFT	STAINLESS STEEL	* 44013-02 (424-LL)	1
19	PIPE PLUG (1/4" NPT)	PLATED STEEL	* 1071918 (PLZ-0008)	1

SPRING ASSIST CLOSED MODEL

ITEM NO.	DESCRIPTION	STD	PART NUMBER	QTY.
20	CAP, SPRING ASSIST CLOSED	CAST IRON	* 1074208 (424-CC)	1
21	RETAINER NUT	BRASS	* 1074274 (424-TT)	1
22	O-RING, 2-020	BUNA-N	* 1071674 (ORB-020)	1
23	SPRING	STAINLESS STEEL	* 1074270 (424 SS)	1
24	CENTERING NUT	STAINLESS STEEL	* 1074276 (424-X)	1
25	PIPE PLUG (1/8" NPT)	BRASS	* 1071903 (PLB-0007)	1

SPRING ASSIST OPEN MODEL

ITEM NO.	DESCRIPTION	STD	PART NUMBER	QTY.
26	DIAPH. PLATE, 424	STAINLESS STEEL	* 43728	1
27	SPRING	STAINLESS STEEL	* 1236766	1

SEE SHEET 1 FOR STANDARD NORMALLY OPEN MODEL

THE COMPONENT OR PRODUCT DESCRIBED IN THIS DOCUMENT MUST COMPLY WITH RoHS 3 EU (EUROPEAN UNION) DIRECTIVE 2015/863

THIS DOCUMENT IS SOLELY THE PROPERTY OF AQ-MATIC REPRODUCTION, USE DISCLOSURE, OR TRANSMISSION OF THIS DOCUMENT OR DETAILS CONTAINED HEREIN, IN PART OR IN WHOLE, IS PROHIBITED WITHOUT THE WRITTEN CONSENT OF AQ-MATIC ENGINEERING. THIS DOCUMENT AND ANY COPIES SHALL BE RETURNED TO AQ-MATIC UPON WRITTEN REQUEST.

INTERPRET DIMENSIONS AND TOLERANCES PER ASME Y14.5M -1994

UNLESS OTHERWISE SPECIFIED:
 DIMENSIONS ARE IN INCHES [mm]
 CORNER FILLETS R.005-020 [127-508]
 TOLERANCES:
 ANGLES: ±1°
 1 PLACE .X: ±.100 [2.54]
 2 PLACE .XX: ±.010 [0.25]
 3 PLACE .XXX: ±.005 [0.13]



APPROVALS	DATE
DRAWN	1/20/21
CHECKED BY	
APPROVED	

Buy AQ Matic.com

DESCRIPTION
CATALOG SHEET, VAV4, DIAPHRAGM VALVE

SIZE **C** DWG NO. **1077636** REV. **P**

SCALE 1:2 SOLIDWORKS FORMAT SHEET 2 OF 2